

Infrared Temperature Sensor IR702

- Precise measuring of metals in low temperature range
- Linear 4-20mA output
- Easy configuration via USB with the novasens Config-software
- Parameterization and network integration via ModBus RTU protocol
- Compact sensor housing with integrated sensor electronics
- USB cable included
- Robust sensor housing made of stainless steel IP65



The novasens IR702 infrared temperature sensor is the right choice for contactless temperature measurement of metals especially in the low temperature range. The measuring ranges are going from 45°C up to 2000°C.

The IR702 sensor can be adjusted to measure different metals during operation using the ModBus RTU protocol or via USB port with the novasens Config software on the PC/Laptop.

Technical Data

Measuring ranges	45°C-300°C, 250°C-1000°C, 450°C-2000°C
Spectral range	2.2 µm
Emissivity correction	1,0 to 0,1 adjustable
Dimensions	Length 61mm x 28mm diameter including cable gland
Permissible ambient operating temperature	0°C to +70°C (additional sensor cooling case for higher temperatures is available)
Distance to measuring spot	15:1 25:1 75:1
Accuracy	+/-2°C or +/- 1% of reading, whichever is greater
Repeat accuracy	+/-0,5°C or +/- 0,5% of reading, whichever is greater
Reaction time	200ms
Resolution	1/10°C
Outputs	4-20mA (2-wire), USB 2.0 using Modbus protocol
Weight	155 gram (sensing head with 1m cable)
Housing material	Stainless Steel
Protection class	IP65
Supply voltage	6 – 24VDC
Delivery scope	Sensing head with mounting nut, removable USB cable 1.8m and 4-20mA output cable 1m length
Conformity	RoHS-conformity, CE-Sign
Article number	0200702

Dimensions

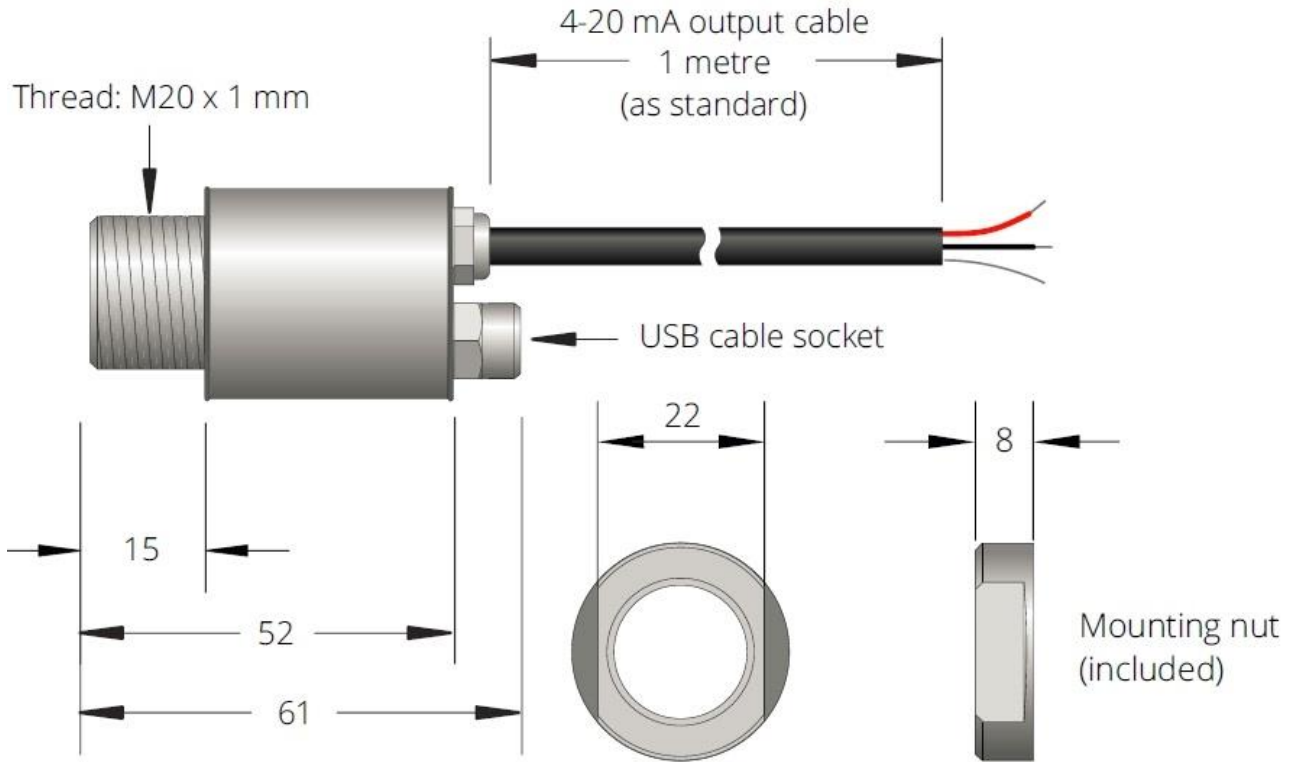

Optical Specifications

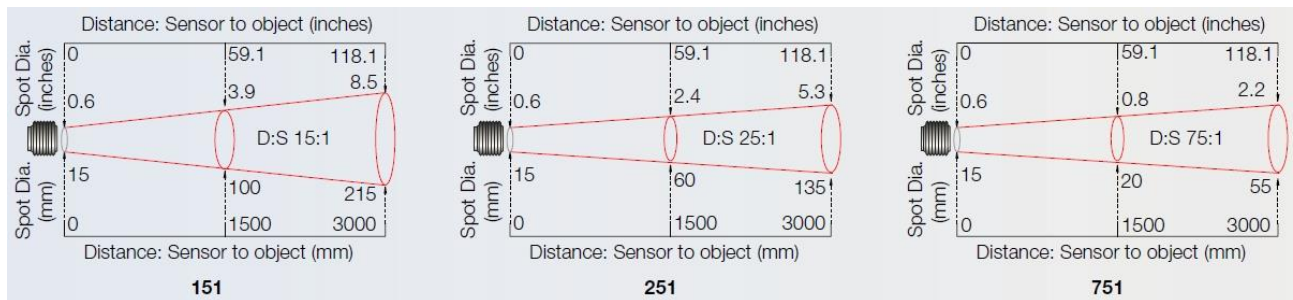

MINIMUM MEASURABLE TEMPERATURE

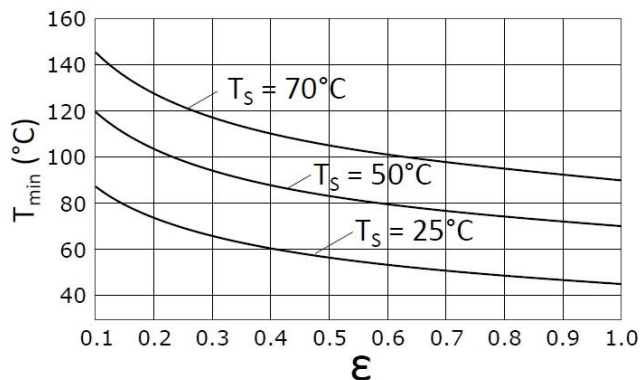

Graph showing the minimum measurable object temperature (T_{min}), determined by surface emissivity (ϵ) and sensor temperature (T_s).

novasens Config-Software

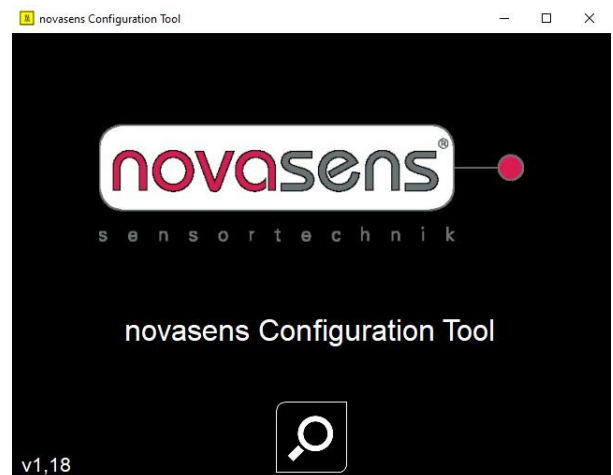

Options

Attachment for air cooling/lens cleaning



Sensor attachment for use in hot or dirty environments. With compressed air connection for air cooling and lens cleaning.
ArtNr. 07AC

Attachment Laserpointer



Sensor attachment with laser pointer for precise alignment of the sensor over long measuring distances.
ArtNr. 07LP

Attachment for watercooling/air lens cleaning



Sensor attachment for use in very hot and dirty environments close to heat sources. With connection for water cooling and air connection for lens cleaning.
ArtNr. 07WCAC

Adjustable bracket



Adjustable bracket for mounting and flexible aligning of the sensor
ArtNr. 07AB

IR702-xxx-x Order Number

